

LINEAR

VP0645



**MOTOR FREE
PISTON SYSTEM**



Airflow & Power Consumption

Specifications

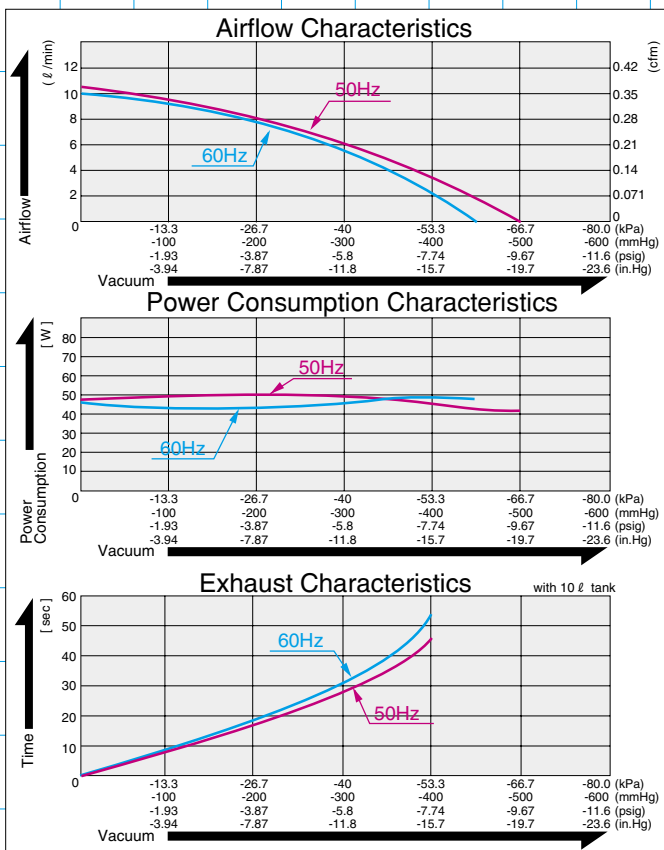

	(SI)	(EURO)	(U.S.A.)
Attainable Vacuum	-60 kPa (-450 mmHg)	-600 mbar	-17.7 in.Hg
Free Air Displacement	10 l/min		0.35 cfm
Rated Voltage	115 V AC or 230 V AC		
Power Consumption	48 W or 50 W		
Rated Frequency	60 Hz or 50 Hz		
Life Expectancy	3,000 hours		
Inlet	15 mm O.D. hose nipple		
Outlet	ISO Rc 1/4 (female threaded)		
Duty Cycle	Continuous		
Coil Insulation Class	E or its equivalent (JETL)		
Mounting Dimensions	68 (L) x 84 (W) mm	2-11/16" (L) x 3-5/16" (W)	
Gross Weight	3.2 kg	7.1 Lbs.	
Leadwire Length	200 mm	7-7/8"	

Please read the page of "How to Use This Catalog" first for correct use of compressors and pumps.
*Operations at higher than -60kPa need an additional leak valve or relief valve on the inlet piping.

Application Examples

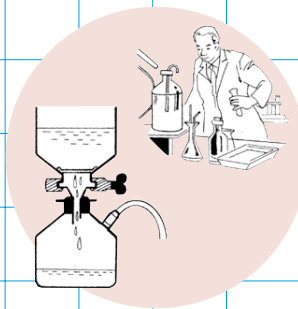

Liquid Purification

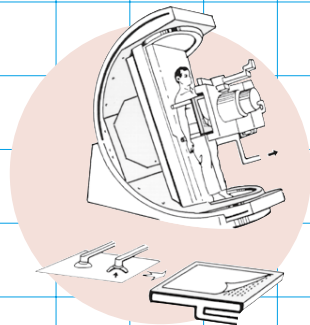

X-ray Film Positioning

Sketch Drawing and Mounting Dimensions Diagram (mm)

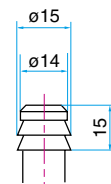
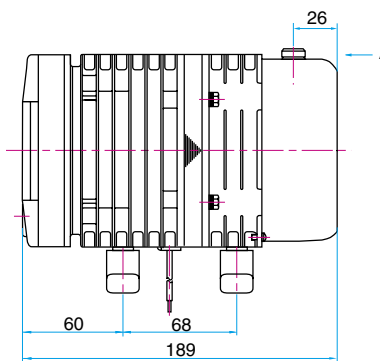
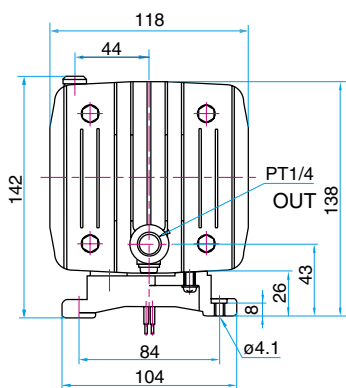

View A
Inlet details