

VSO[®] - MI Miniature Proportional Valve

Thermally Compensated Proportional Valve



Typical Applications

- Ventilators
- Oxygen Concentrators
- Oxygen Conservers
- Anesthesia Delivery & Monitors
- Pressure & Flow Control
- Blood Pressure Monitoring

Performance Data

Physical Properties

Valve Type:	2-Way Normally Closed
Media:	Air, carbon dioxide, nitrogen, oxygen and helium
Operating Environment:	32 - 140°F (0 - 60°C)
Storage Temperature:	-40 to 158°F (-40 to 70°C)
Length:	1.77 in (44.9 mm)
Width:	0.66 in (16.7 mm)
Height:	0.74 in (18.8 mm)
Porting:	Manifold mount with integrated filters and FKM manifold seals
Weight:	1.23 oz (34.9 g)
Mounting Requirements:	See Table 2

The VSO[®]- MI is a miniature proportional valve designed for medical equipment manufacturers. Based upon Parker Hannifin's benchmark VSO[®] design, the VSO[®]- MI miniature proportional valve incorporates thermal compensation to provide precise flow control and stability over a wide range of media. Unlike competitive valves in its class, the VSO[®]- MI miniature proportional valve has been tested to U.S. Pharmacopoeia (USP) Class VI requirements making it easier to achieve system compliance for toxicity and sensitivity. With integrated filtration, captive O-rings, flush manifold mount capability, low power consumption and light weight, the VSO[®]- MI is an efficient miniature proportional valve ideally suited for manufacturers of portable and stationary medical equipment.

Features

- Thermally compensated to maintain precision flow and accuracy
- Tested to USP Class VI requirements to ease system compliance
- Proven performance tested to 25 million life cycles
- Integrated filters to protect the valve from damaging upstream and downstream particulates
- Cleaned for Oxygen Service Use
- RoHS compliant 

Physical Properties

Internal Volume:	0.031 in ³ (0.508 cm ³)
Filtration:	Integrated 40 micron filters (inlet and outlet ports)
Flow Direction:	Inlet Port Port 2 Outlet Port Port 1

Electrical

Power:	2.0 Watts maximum
Voltage:	See Table 3
Electrical Termination:	18.5 in (47 cm) Wire Leads, Quick Disconnect Spade, PC Mount

Wetted Materials

Valve Body:	Polybutylene terephthalate (PBT)
Stem Base:	430 FR Stainless Steel and Brass C3600 HT
All Others:	FKM, 430 FR Stainless Steel, 300 Series Stainless Steel, Brass C3600 HT

Performance Characteristics

Leak Rate:	The leakage shall not exceed the following values: Internal 0.2 SCCM of N ₂ over rated pressure range External 0.016 SCCM of N ₂ at 150 psig
Pressure:	Model 3: 0 to 150 psid (10.34 Bar) Model 5: 0 to 100 psid (6.89 Bar) See Table 1
Vacuum:	0-27 in Hg (0-686 mm Hg)
Orifice Sizes:	0.031 in (0.79 mm) 0.051 in (1.30 mm)
Hysteresis:	7% of full scale current (Typical) 15% of full scale current (Max)

VSO is a registered trademark of Parker Hannifin Corporation.



VSO®- MI Miniature Proportional Valve

**VSO®- MI Typical Air Flow with 13.5 VDC Coil @ 25 psid (1.7 bar)
All Models**

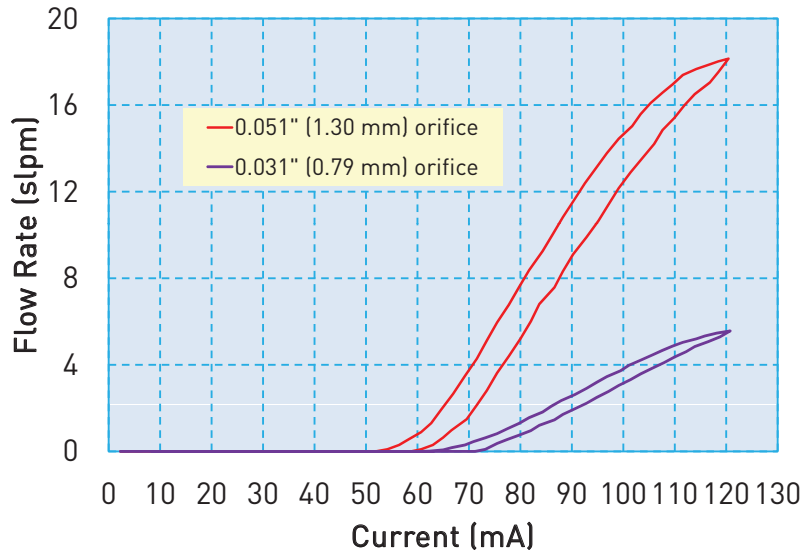

**VSO®- MI Pressure vs. Flow Curves @ 20°C
Models 3 & 5**

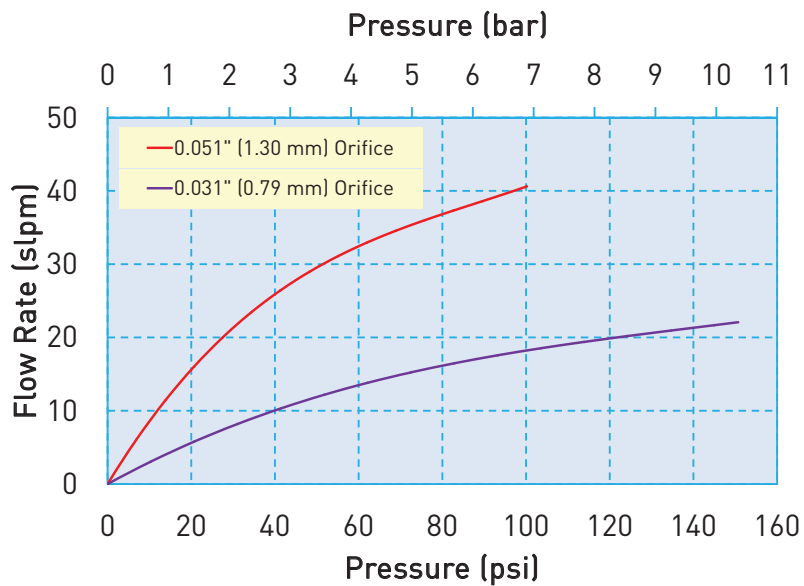
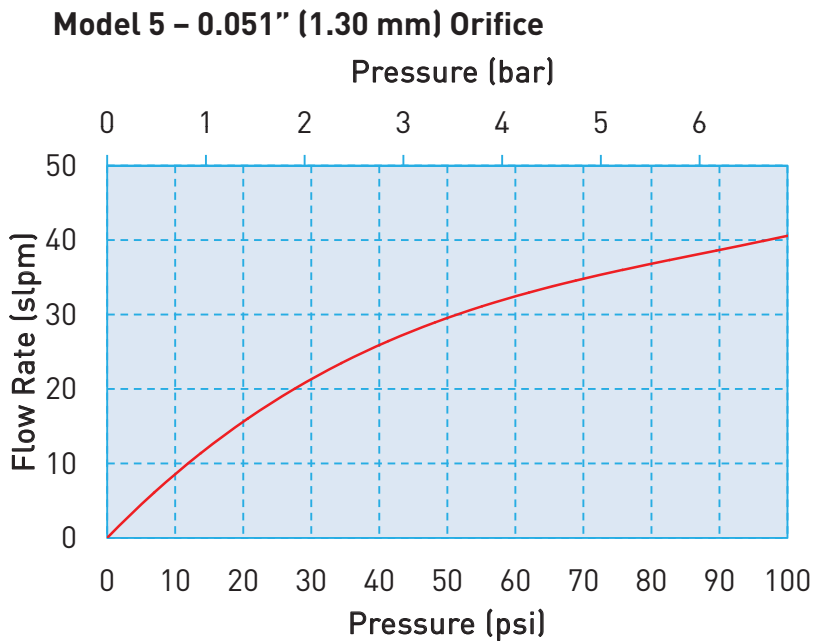
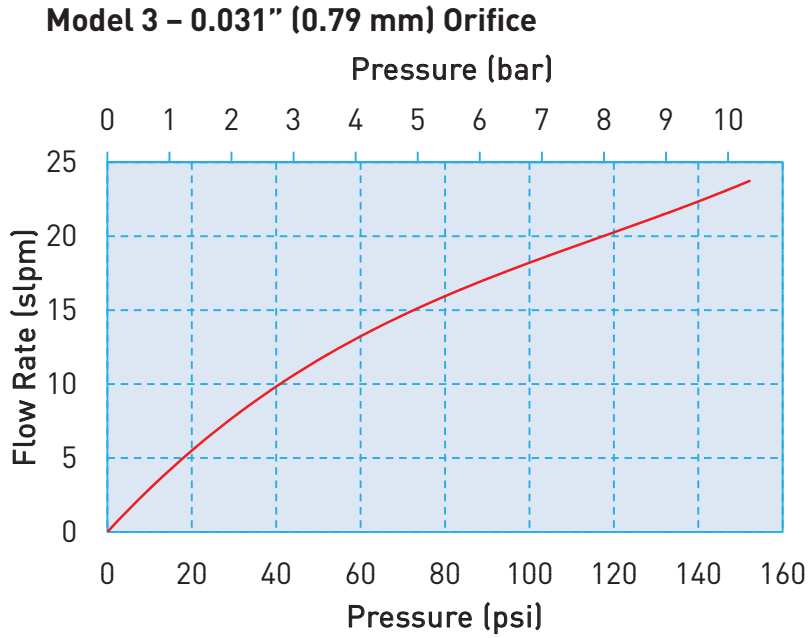

Table 1: Pressure and Flow Capabilities

Model No.	Orifice Diameter	Cv at Maximum Pressure	Maximum Inlet Pressure	Maximum Differential Pressure
3	0.031" (0.79 mm)	0.010	150psi (10.34 bar)	150psig (10.34 bar)
5	0.051" (1.30 mm)	0.025	150psi (10.34 bar)	150psig (10.34 bar)

VSO[®]- MI Miniature Proportional Valve

VSO[®]- MI Sizing Charts



VSO®- MI Miniature Proportional Valve

Pneumatic Interface



VSO®- MI Basic Valve Dimensions

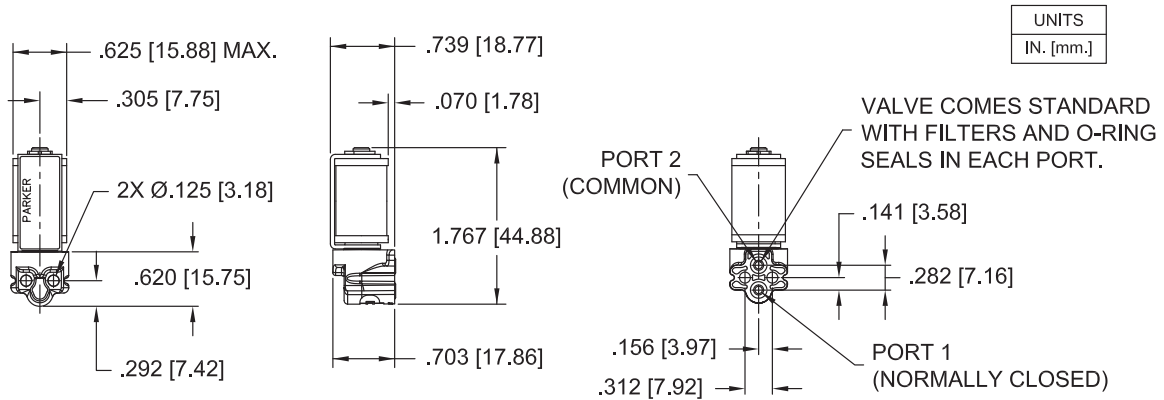

Table 2: Mounting Requirements

Mounting Screw Sizes (Pan Head Machine Screw)	Mounting Screw Torque
4-40 x 3/4"	45 oz-in
M3 x 20 mm	0.32 N.m.

VSO®- MI Miniature Proportional Valve

Electrical Interface

Coil Type: Wire Leads (for Terminal Block Connection)

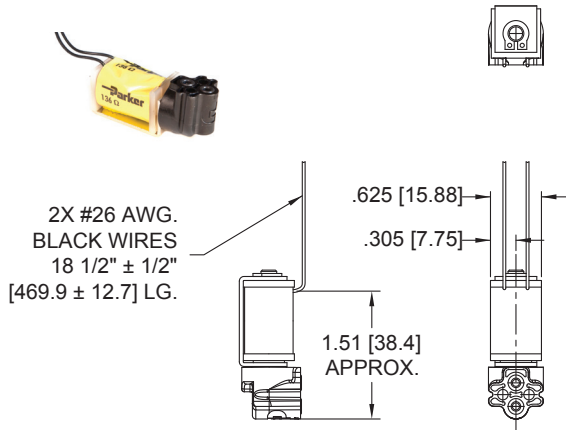

Coil Type: Quick Connect Spade (for Female Spade Terminal Connection)

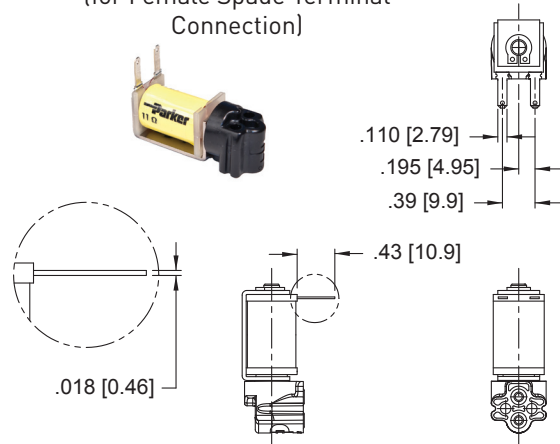

Coil Type: 4 PC Pins (For PCB solder mount connection)

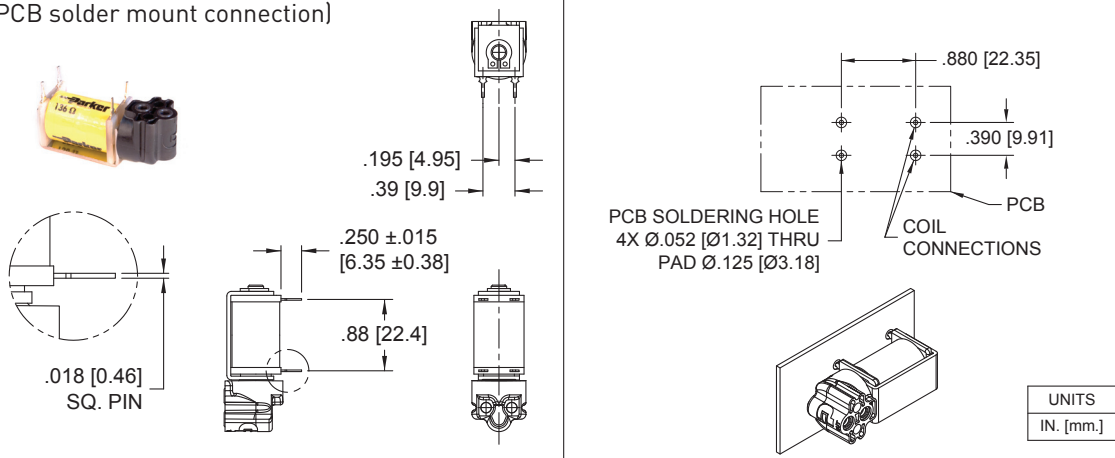

Table 3: Electrical Requirements

Maximum Supply Voltage (VDC)	Nominal Coil Resistance (Ohms) @ 20°C	Control Current at Maximum Flow (mA)
5.5	11	304
13.5	68	125
29	274	66

VSO®-MI Miniature Proportional Valve

VSO®-MI Installation and Use

Typical Valve Set-up

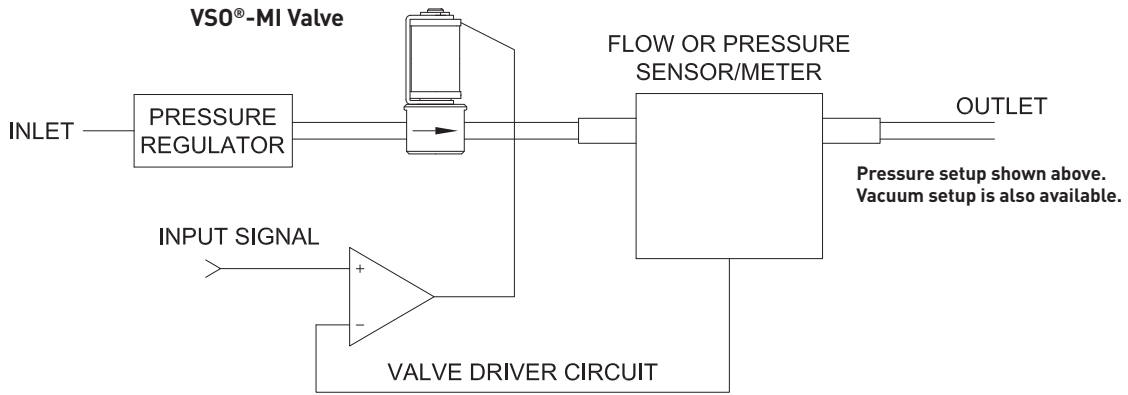

Valve Electrical Control

Basic Control:

The VSO®-MI valve can be controlled by either voltage or current; however, it is highly recommended that current control be employed to ensure the most repeatable valve flow performance.

PWM Control:

For PWM control, the signal applied to the valve should have a frequency between 5-12kHz. Optimum frequency will be application dependent.

Suggested VSO®-MI Current Driver Schematic

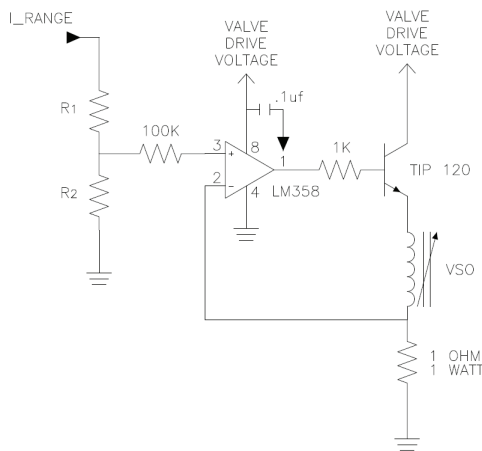

This simple current driver circuit draws only 1 mA at the input control (0-5VDC) and provides control for any VSO®-MI valve configuration regardless of valve voltage or resistance.

Table 4 (below) describes the recommended R1 and R2 resistor values based upon the full shut-off current.

Table 4: Selectable Resistor Values for a Low Current (1mA) LM358-Based Current Driver

Minimum Available Voltage (VDC)	Valve Drive Voltage (VDC)	Nominal Coil Resistance @ 20°C (Ohms)	Input Current for Full Flow (mA)	R1 (Ohms)	R2 (Ohms)
5.5	7.5	11	304	5100	330
13.5	15.5	68	125	4420	113
29.0	31.0	274	66	4990	66.5

VSO®-MI Miniature Proportional Valve

Recommended VSO®-MI Manifold Dimensions

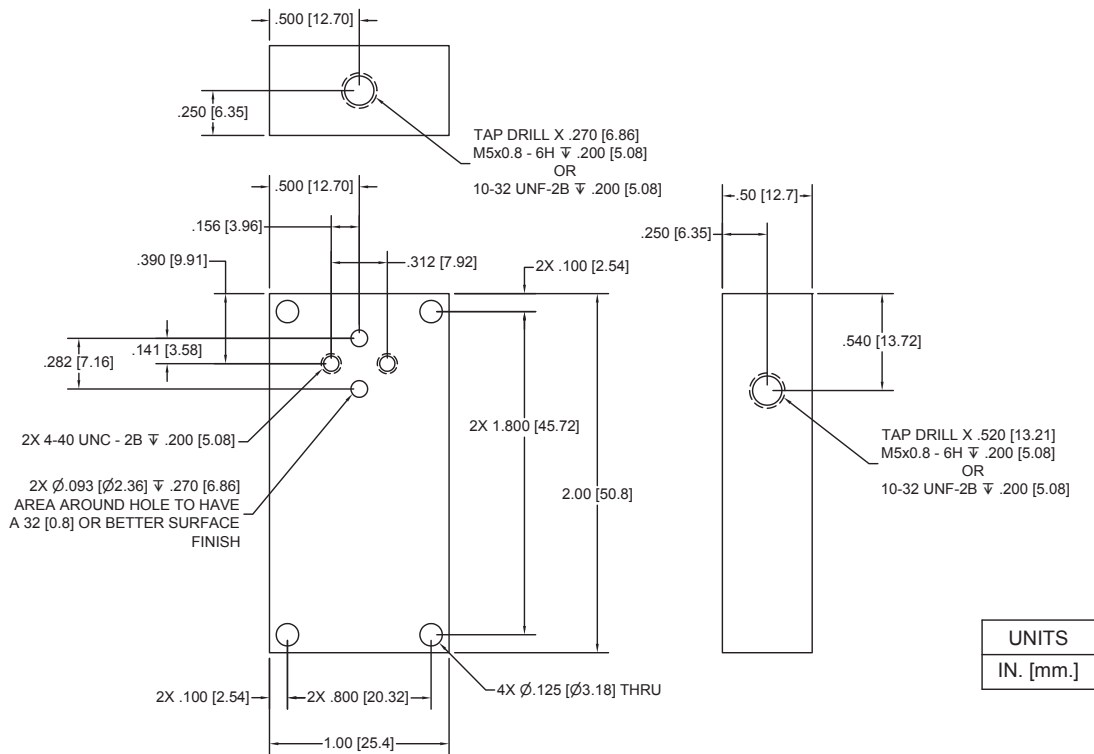

Miniature Proportional Valves

Spares and Accessories

O-Ring (Manifold Seal) Dimensions
 190-007059-001 (2 supplied with each valve)

I.D. = .114 ±.006 [2.90 ±0.15]
 W = .039 ±.003 [0.99 ±0.08]
 O.D. = .192 [4.88] REFERENCE

Screw 4-40 x 3/4" Pan Head, Phillips
 191-000115-012 (2 required for each valve)

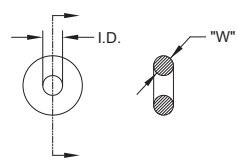

VSO®- MI Miniature Proportional Valve

Ordering Information

Sample Part ID	931	3	1	1	05	1	000
Description	Series	Model Number: Operating Pressure / Orifice Size	Elastomer / Body	Pneumatic Interface	Voltage/ Coil Selection	Electrical Interface	
Options	931	3: 150 psid / 0.031" (0.79 mm) 5: 100 psid / 0.051" (1.30 mm)	1: FKM / PBT	1: Manifold Mount* *Includes integrated 40 micron filters and FKM manifold seals	05: 5.5 VDC / 11 Ohm 13: 13.5 VDC / 68 Ohm 29: 29 VDC / 274 Ohm	1: Wire Leads, 18" (45.7 cm) 2: Quick Connect, Spade 3: PC Board Mount, 4 Pin	

Accessories	
190-007059-001: O-ring, FKM, 0.114" ID x 0.039" Thick*	*Supplied with each valve. Used as a seal between the valve body and manifold.
191-000115-012: Screw, Pan head, 4-40 x 3/4", Stainless Steel**	**Not supplied with the valve. Used to mount the valve to a manifold.



NOTE: In order to provide the best possible solution for your application, please provide the following requirements when contacting Applications Engineering:

- Media, Inlet & Outlet Pressures
- Minimum Required Flow Rate
- System Supply Voltage or Current
- Flow Media & Ambient Temperature Range

Please click on the Order On-line button (or go to www.parker.com/precisionfluidics/vsomi) to configure your VSO®- MI Miniature Proportional Valve. For more detailed information, visit us on the Web, or call and refer to Performance Specification #790-002356-001 and Drawing #890-003292-001.

