

VSO® Miniature Proportional Valve

Thermally Compensated Proportional Valve



Typical Applications

- Gas Chromatography
- Mass Spectrometry
- Ventilators
- O₂ Concentrators/Conservers
- Anaesthesia Delivery & Monitors
- Pressure & Flow Control
- Mass Flow Control

Physical Properties

Valve Type:	2-Way Normally Closed
Media:	Air, argon, helium, hydrogen, methane, nitrogen, oxygen, & others
Operating Environment:	32 to 131°F (0 to 55°C)
Storage Temperature:	-40 to 158°F (-40 to 70°C)
Length:	1.79 in (45.3 mm)
Width:	0.63 in (15.9 mm)
Height:	0.67 in (17.0 mm)
Porting:	1/8" (3 mm) barbs or 10-32 female; manifold mount (available with screens)
Weight:	2.2 oz (63 g)

The VSO® miniature proportional valve provides enhanced flow control for applications where precise control flow control is required up to 56 slpm. The VSO® miniature proportional valve provides precise flow control of gas in proportion to input current. The valve can be controlled with either DC current or pulse width modulation along with closed loop feedback to deliver optimal system performance. Together with its ability to provide precise control over varying temperatures and media types, the VSO® miniature proportional valve is ideally suited for manufacturers of medical and analytical equipment.

Features

- Enables precise flow control for improved instrument accuracy
- Thermally compensated to maintain precise flow over a wide range of media
- Computer automated calibration and serialization for performance traceability
- Cleaned for Oxygen and Analytical Service use
- Proven performance tested to 100 million life cycles
- RoHS compliant 

Physical Properties

Internal Volume:	0.031 in ³ (0.508 cm ³)
Filtration: (Suggested and Available)	Models 1 & 2: 17 micron Models 3, 4, 5, & 6: 40 micron
Flow Direction:	Inlet Port Port 2 Outlet Port Port 1

Electrical

Power:	2.0 Watts maximum
Voltage:	See Table 2
Electrical Termination:	18" (45.7 cm) Wire Leads, PC Mount, Quick Disconnect Spade

Wetted Materials

Series 11 Body:	360 HO ₂ Brass
Series 25 Body:	Nickel-Plated Brass
Stem Base:	430 FR Stainless Steel and Brass 360 HT
All Others:	FKM; FFKM; 430 FR Stainless Steel; 300 Series Stainless Steel

Performance Characteristics

Leak Rate:	The leakage shall not exceed the following values: Internal 0.2 SCCM of He with a differential pressure of 1 psid, 25 psid and 150 psid External 0.016 SCCM of He at 150 psi
Pressure:	0 to 50 psi (3.45 bar) 0 to 75 psi (5.17 bar) 0 to 100 psi (6.89 bar) 0 to 150 psi (10.34 bar) See Table 1
Vacuum:	0-27 in Hg (0-686 mm Hg)
Orifice Sizes:	0.010 in (0.25 mm) 0.020 in (0.51 mm) 0.030 in (0.76 mm) 0.040 in (1.02 mm) 0.050 in (1.27 mm) 0.065 in (1.65 mm)
Hysteresis:	7% of full scale current (Typical) 15% of full scale current (Max)

VSO is a registered trademark of Parker Hannifin Corporation.



VSO[®] Thermally Compensated Proportional Valve

Typical Air Flow with 20 VDC Coil @ 25psid (1.7 bar) All Models

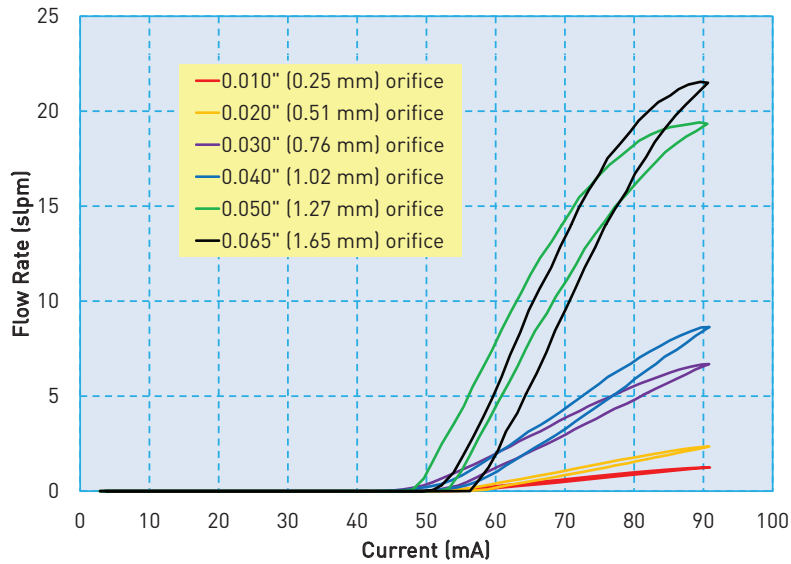

VSO[®] Pressure vs Flow Curves Models 1-6

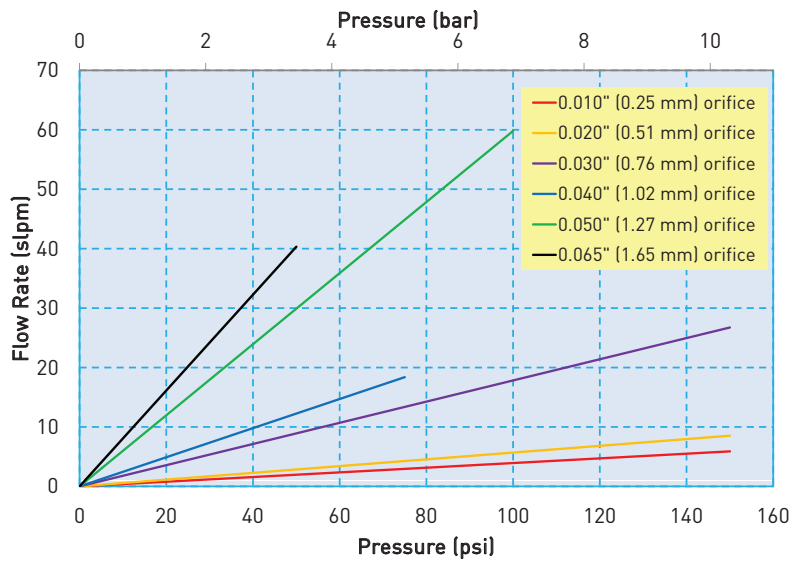

Table 1: Pressure and Flow Capabilities

Orifice Diameter	Maximum Operating Inlet Pressure	Maximum Operating Pressure Differential
0.010 in (0.25 mm)	150 psig (10.34 bar)	150 psid (10.34 bar)
0.020 in (0.51 mm)	150 psig (10.34 bar)	150 psid (10.34 bar)
0.030 in (0.76 mm)	150 psig (10.34 bar)	150 psid (10.34 bar)
0.040 in (1.02 mm)	150 psig (10.34 bar)	75 psid (5.17 bar)
0.050 in (1.27 mm)	150 psig (10.34 bar)	100 psid (6.89 bar)
0.065 in (1.65 mm)	150 psig (10.34 bar)	50 psid (3.45 bar)

VSO[®] Thermally Compensated Proportional Valve

VSO[®] Sizing Charts

Model 1 - 0.010" (0.25 mm) Orifice

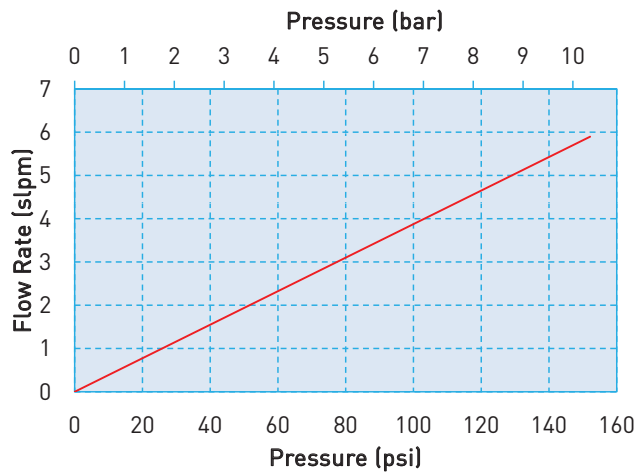

Model 2 - 0.020" (0.51 mm) Orifice

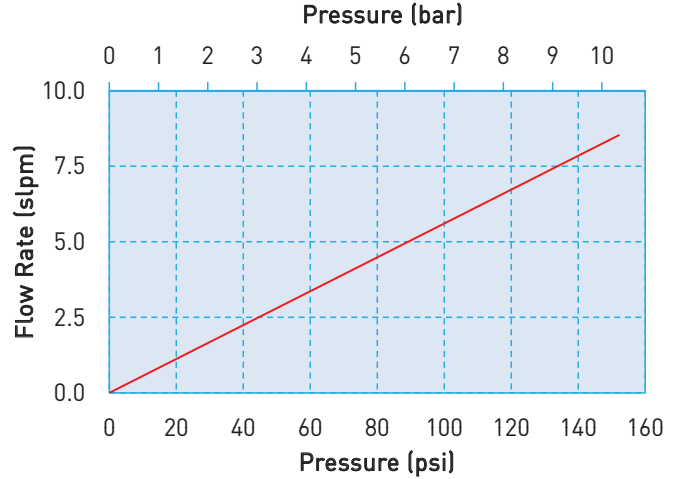

Model 3 - 0.030" (0.76 mm) Orifice

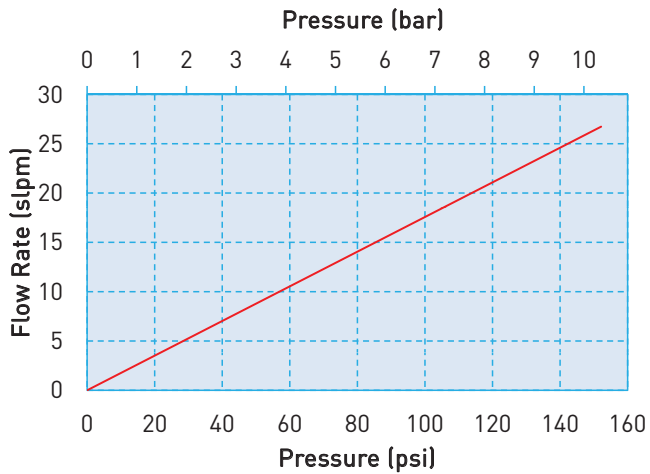

Model 4 - 0.040" (1.02 mm) Orifice

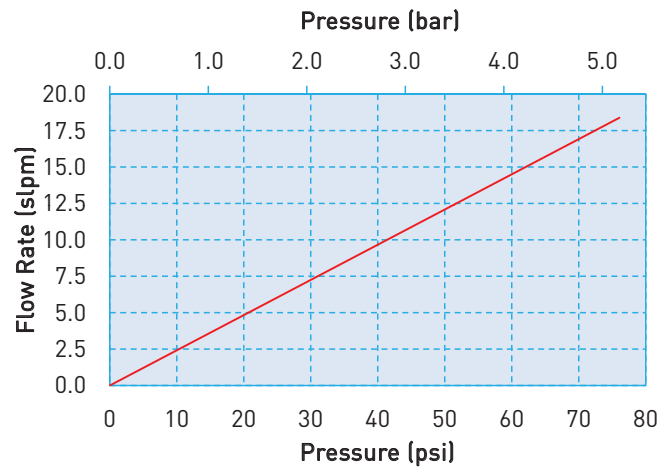

Model 5 - 0.050" (1.27 mm) Orifice

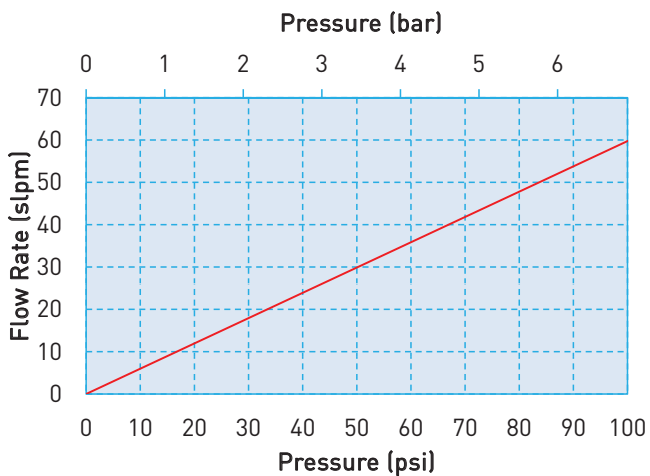

Model 6 - 0.065" (1.65 mm) Orifice

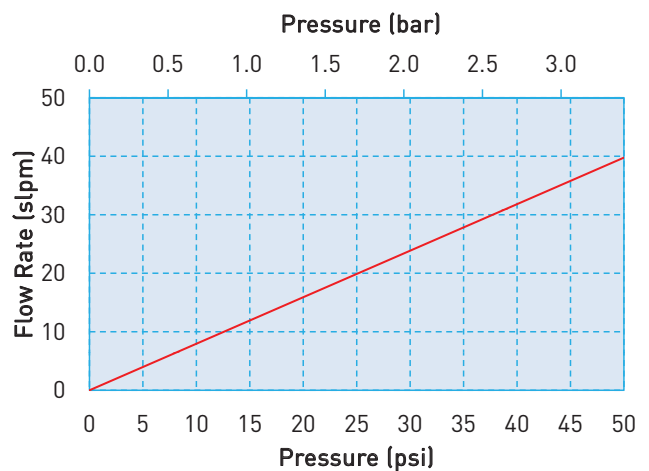

VSO® Thermally Compensated Proportional Valve

Pneumatic Interface

VSO® Series 11 Manifold Mount



VSO® Series 11 Barbed



VSO® Series 25 10-32 Threaded



VSO® Series 11 Manifold Mount and Barbed Body Basic Valve Dimensions

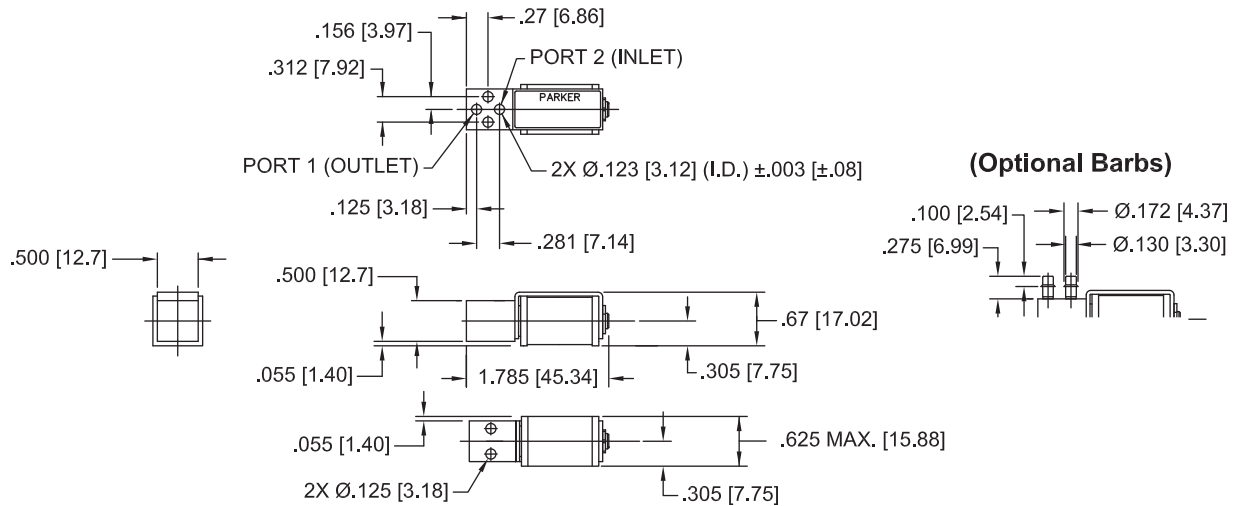

VSO® Series 25 10-32 Threaded Body Basic Valve Dimensions

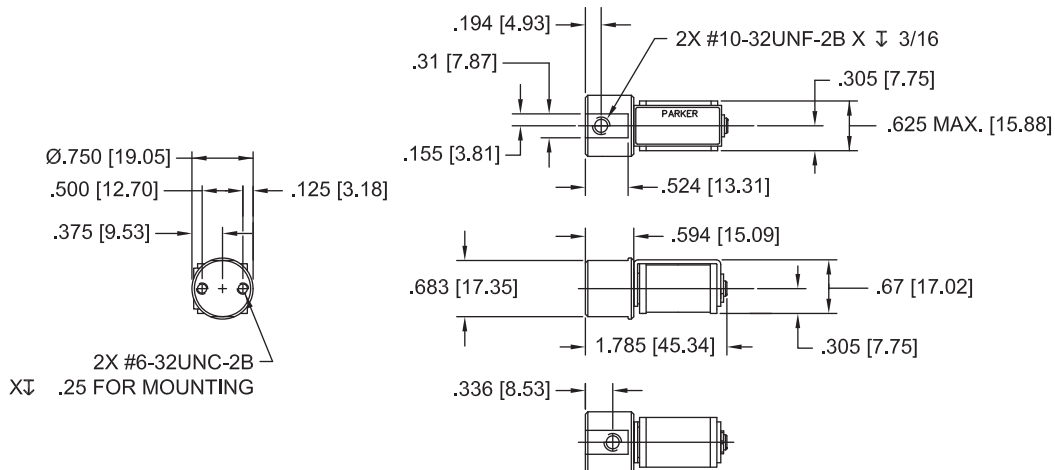

VSO[®] Thermally Compensated Proportional Valve

Electrical Interface

Coil Type: Wire Leads

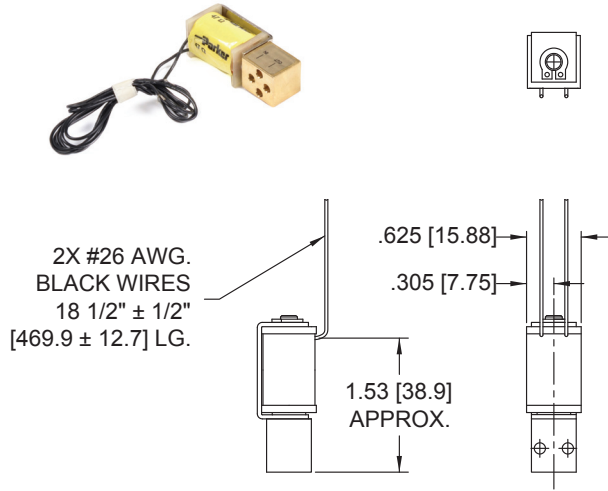

Coil Type: 4 PC Pin*

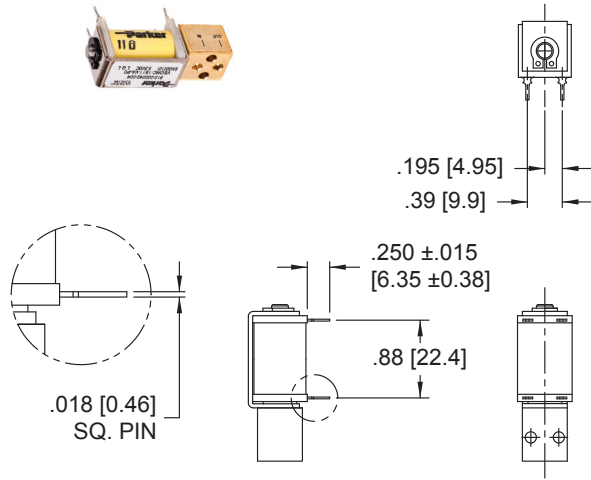

Coil Type: Quick Connect Spade

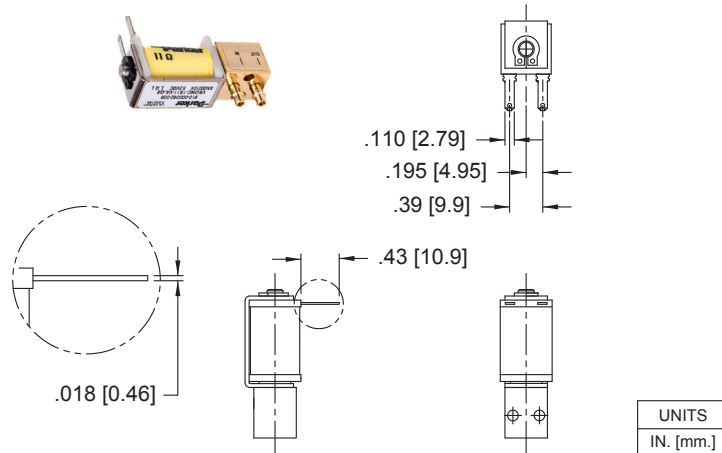

*PCB Pin Layout (Coil Type 4 PC Pin)

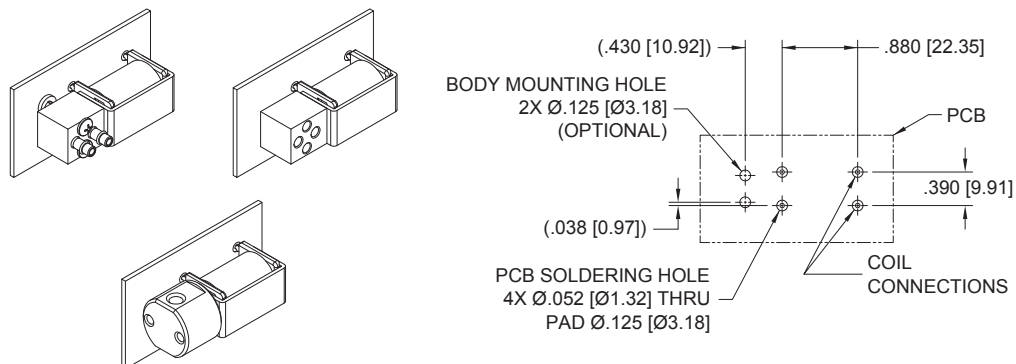

VSO[®] Thermally Compensated Proportional Valve

Table 2: Electrical Requirements

Minimum Available Voltage (VDC)	Nominal Coil Resistance @ 20 °C (Ohms)	Input Current for Full Flow (mA)
5.5	11	304
8.0	23	212
11.5	47	152
13.5	68	125
20.0	136	91
29.0	274	66
41.0	547	47
56.0	1094	32

VSO[®] Installation and Use

Typical Valve Set-up

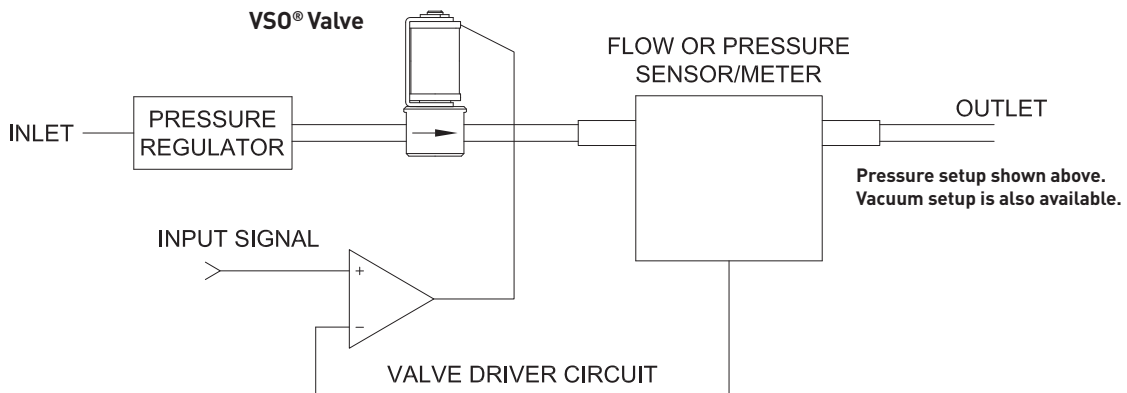

Valve Electrical Control

Basic Control:

The VSO[®] valve can be controlled by either voltage or current; however, it is highly recommended that current control be employed to ensure the most repeatable valve flow performance.

PWM Control:

For PWM control, the signal applied to the valve should have a frequency between 5-12kHz. Optimum frequency will be application dependent.

VSO® Thermally Compensated Proportional Valve

Suggested VSO® Current Driver Schematic

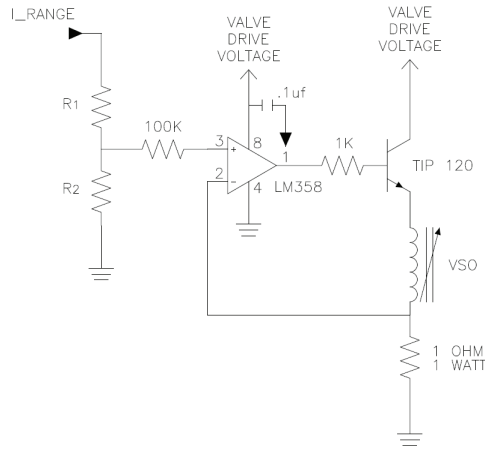

This simple current driver circuit draws only 1 mA at the input control (0-5VDC) and provides control for any VSO® valve configuration regardless of valve voltage or resistance.

Table 3 (below) describes the recommended R1 and R2 resistor values based upon the full shut-off current.

Table 3: Selectable Resistor Values for a Low Current (1 mA) LM358-Based Current Driver

Minimum Available Voltage (VDC)	Valve Drive Voltage (VDC)	Nominal Coil Resistance @ 20°C (Ohms)	Input Current for Full Flow (mA)	R1 (Ohms)	R2 (Ohms)
5.5	7.5	11	304	5100	330
8.0	10.0	23	212	4990	221
11.5	13.5	47	152	5100	160
13.5	15.5	68	125	4420	113
20.0	22.0	136	91	4420	82
29.0	31.0	274	66	4990	66.5

Manifold & O-Ring Dimensions & Design

Not shipped with valves.

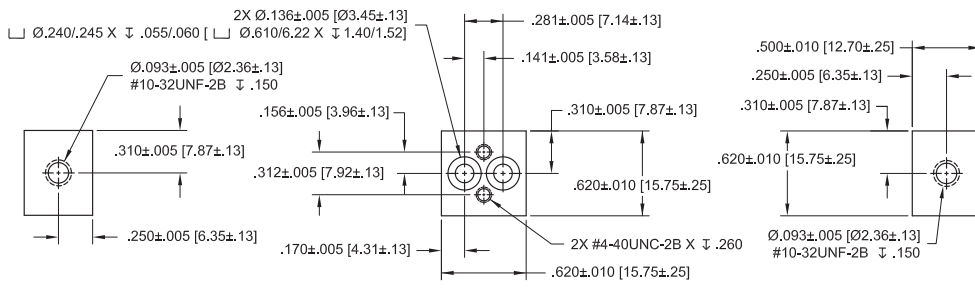

O-RING DIMENSIONS
 I.D. = Ø.114 ±.005 [Ø2.90 ±.013]
 W = .070 ±.003 [1.78 ±.008]
 O.D. = Ø.254 [Ø6.45] REFERENCE

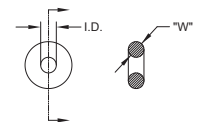

VSO® Thermally Compensated Proportional Valve

Accessories

O-Ring (Manifold Seal) Dimensions
190-007024-002 (2 required for each valve)

I.D. = $\varnothing .114 \pm .005$ [$\varnothing 2.90 \pm 0.13$]
W = $.070 \pm .003$ [1.78 ± 0.08]
O.D. = $\varnothing .254$ [$\varnothing 6.45$] REFERENCE

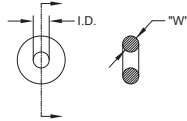

Screw 4-40 x 5/8" Pan Head, Phillips
191-000115-010 (2 required for each valve)



Ordering Information

Sample Part ID	VSONC	1	S	11	V	A	F	8
Description	Standard	Model Number: Maximum Operating Pressure / Orifice Size	Series	Body Series	Elastomer/ Body Material	Coil Voltage/Coil Resistance/Coil Current*	Electrical Interface	Pneumatic Interface
Options		1: 150 psi / 0.010" (0.25 mm) 2: 150 psi / 0.020" (0.51 mm) 3: 150 psi / 0.030" (0.76 mm) 4: 75 psi / 0.040" (1.02 mm) 5: 100 psi / 0.050" (1.27 mm) 6: 50 psi / 0.065" (1.65 mm)		11: Series 11 25: Series 25	V: FKM / Brass C: FFKM / Brass I: FFKM / Stainless Steel H: FKM / Stainless Steel	A: 5.5 VDC / 11 Ohm / 0.304 Amp B: 8 VDC / 23 Ohm / 0.212 Amp C: 11.5 VDC / 47 Ohm / 0.152 Amp D: 13.5 VDC / 68 Ohm / 0.125 Amp E: 20 VDC / 136 Ohm / 0.091 Amp F: 29 VDC / 274 Ohm / 0.066 Amp * Maximum voltage for continuous full flow, ambient temperature 55°C	F: Wire Leads, 18" (45.7 cm) P: PC Board Mount, 4 Pin Q: Quick Connect, Spade	0: Manifold Mount 1: Manifold Mount w/screens 5: 10-32 Threaded Female (Series 25) 8: 1/8" (3 mm) Barbs

Accessories	
190-007024-002: O-ring, FKM, 0.114" ID x 0.070" Thick*	* Not supplied with the valve. Used as a seal between the valve body and manifold.
191-000115-010: Screw 4-40 x 5/8" Pan Head **	**Not supplied with the valve. Used to mount the valve to a manifold.



NOTE: In order to provide the best possible solution for your application, please provide the following requirements when contacting Applications Engineering:

- Media, Inlet & Outlet Pressures
- Minimum Required Flow Rate
- System Supply Voltage
- Media & Ambient Temperature Range

Please click on the Order On-line button (or go to www.parker.com/precisionfluidics/vso) to configure your VSO® Thermally Compensated Proportional Valve. For more detailed information, visit us on the Web, or call and refer to VSO® Series 11 Performance Spec. #790-002115-001 and Drawings #890-003022-001 and #890-003022-003. VSO® Series 25 Performance Spec. #790-002115-001 and Drawing # 890-003023-001.

